

TeSys contactors

Model d contactors
Control circuit: a.c.

LC1-D09...D18 (3-pole)

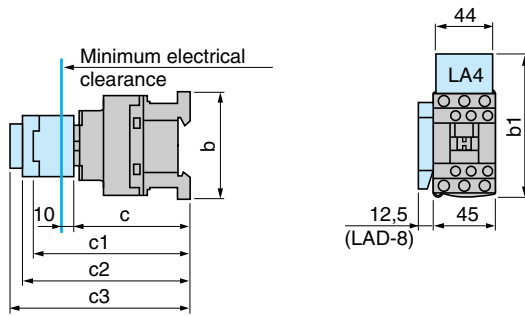

LC1-D25...D38 (3-pole) LC1-DT20...DT60 (4-pole)

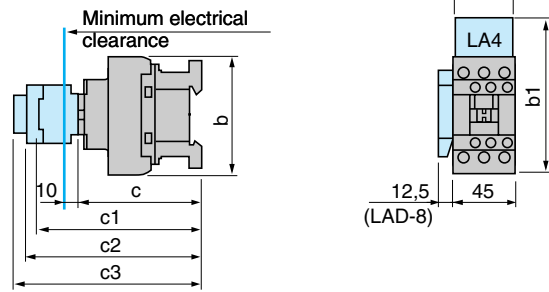

LC1-	D09... D18	D093... D183	D099... D189	D25... D38	D253 & D323	DT20 & DT25	DT203 & DT253	DT32... DT60	DT323 & DT603
b without add-on blocks	77	99	80	85	99	85	99	91	105
b1 with LAD-4BB	94	107	95.5	98	107	98	-	-	-
with LA4-D●2	110 (1)	123 (1)	111.5 (1)	114 (1)	123 (1)	114	-	-	-
with LA4-DF, DT	119 (1)	132 (1)	120.5 (1)	123 (1)	132 (1)	129	-	-	-
with LA4-DR, DW, DL	126 (1)	139 (1)	127.5 (1)	130 (1)	139 (1)	190	-	-	-
c without cover or add-on blocks	84	84	84	90	90	90	90	98	98
with cover, without add-on blocks	86	86	86	92	92	92	92	100	100
c1 with LAD-N or C (2 or 4 contacts)	117	117	117	123	123	123	123	131	131
c2 with LA6-DK10, LAD-6K10	129	129	129	135	135	135	135	143	143
c3 with LAD-T, R, S	137	137	137	143	143	143	143	151	151
with LAD-T, R, S and sealing cover	141	141	141	147	147	147	147	155	155

(1) Including LAD-4BB

LC1-D40...D65 (3-pole)

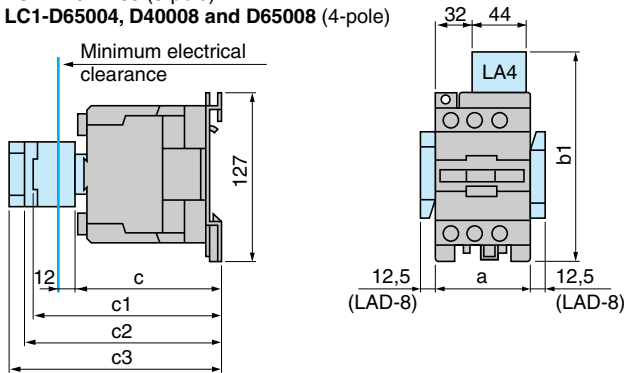

LC1-D80 and D95 (3-pole)

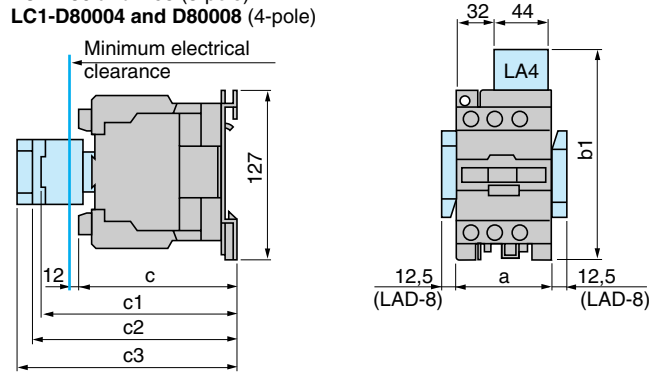

LC1-	D40...D65	D4008	D80 D65004	D95 D65008	D8004	D8008
a	75	85	85	85	96	96
b1 with LA4-D●2	135	135	135	135	135	135
with LA4-DB3	-	-	135	-	-	-
with LA4-DF, DT	142	142	142	142	142	142
with LA4-DM, DR, DW, DL	150	150	150	150	150	150
c without cover or add-on blocks	114	125	125	125	125	140
with cover, without add-on blocks	119	-	130	130	-	-
c1 with LAD-N (1 contact)	139	139	150	150	150	150
with LAD-N or C (2 or 4 contacts)	147	147	158	158	158	158
c2 with LA6-DK	159	159	170	170	170	170
c3 with LAD-T, R, S	167	167	178	178	178	178
with LAD-T, R, S and sealing cover	171	171	182	182	182	182

LC1-D115 and D150 (3-pole)

LC1-D115004 (4-pole)

LC1-	D115 D150	D115004	D115006	D150006	D1150046
a	120	150	120	120	155
b1 with LA4-DA2	174	174	174	174	174
with LA4-DF, DT	185	185	185	185	185
with LA4-DM, DR, DL	188	188	188	188	188
with LA4-DW	188	188	188	-	188
c without cover or add-on blocks	132	132	115	115	115
with cover, without add-on blocks	136	-	-	-	-
c1 with LAD-N or C (2 or 4 contacts)	150	150	150	150	150
c2 with LA6-DK20	155	155	155	155	155
c3 with LAD-T, R, S	168	168	168	168	168
with LAD-T, R, S and sealing cover	172	172	172	172	172

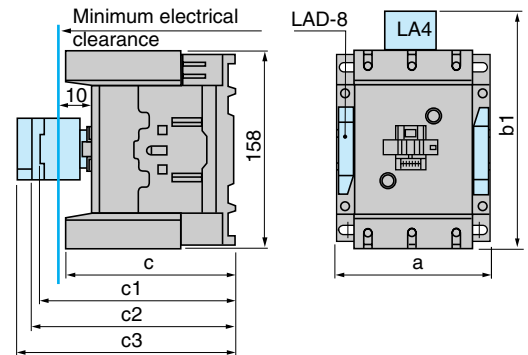

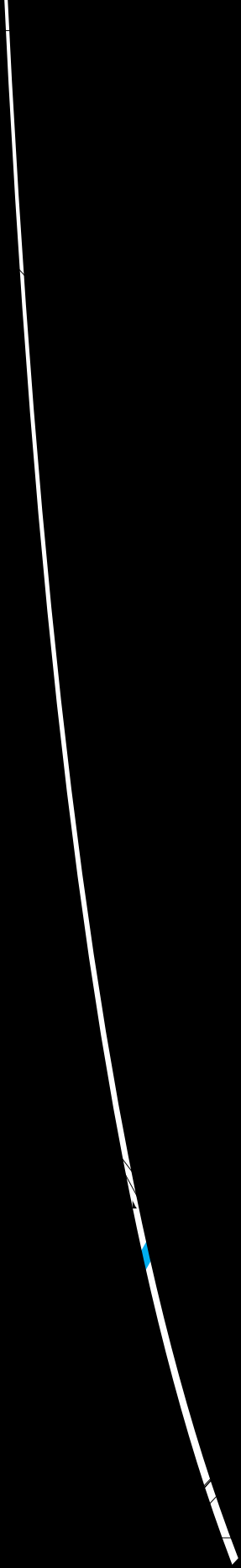

On mounting rail AM1-DP200, DR200 or AM1-DE200 (width 35 mm)
LC1-D09...D38, DT20...DT60

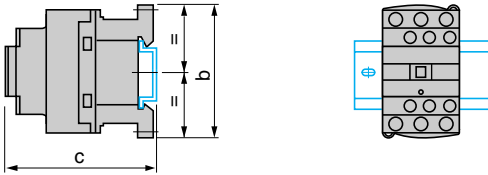

On mounting rail AM1-DL200 or DL201 (width 75 mm)
 On mounting rail AM1-ED●●● or AM1-DE200 (width 35 mm)
LC1-D40 to D95, LP1-D40 to D80

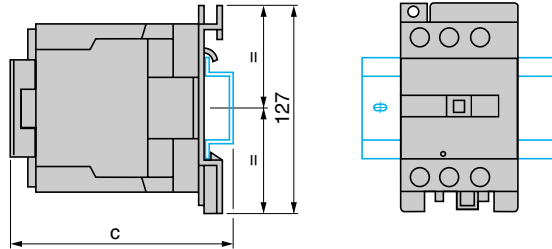

LC1-	D09...D18	D25...D38	DT20 & DT25	DT32... DT60
b	77	85	85	100
c (AM1-DP200 or DR200) (1)	88	94	94	109
c (AM1-DE200) (1)	96	102	102	117

d.c. control circuit

b	77	85	94	109
c (AM1-DP200 or DR200) (1)	97	103	103	118
c (AM1-DE200) (1)	105	110	111	1236

a.c. control circuit

LC1-	D40...D65	D80 & D95
c (AM1-DL200) (1)	136	147
c (AM1-DL201) (1)	126	137
c (AM1-ED●●● or DE200) (1)	126	137

d.c. control circuit

LC1-	D40...D65	D80 & D95
c (AM1-DL200) (1)	193	203
c (AM1-DL201) (1)	183	203

LP1-	D40	D65	D80
c (AM1-DL200)	188	188	198
c (AM1-DL201)	178	178	198

(1) with safety cover

On 2 mounting rails DZ5-MB at 120 mm centres
LC1-D115, D150

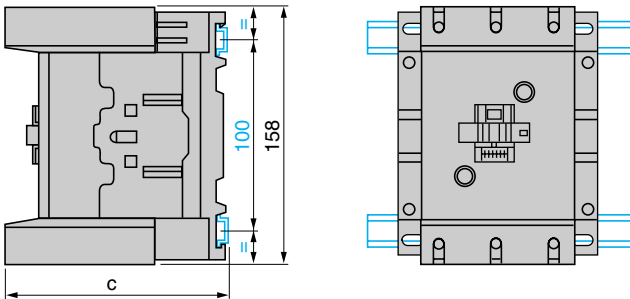

(1) with safety cover

a.c. or d.c. control circuit

LC1-	D115 & D150	D1156 & D1506
c (AM1-DP200 or DR200)	134.5	117.5
c (AM1-DE200 or ED●●●)	142.5	125.5

On 2 mounting rails DZ5-MB at 120 mm centres
LC1-D40...D95, LP1-D40...D80

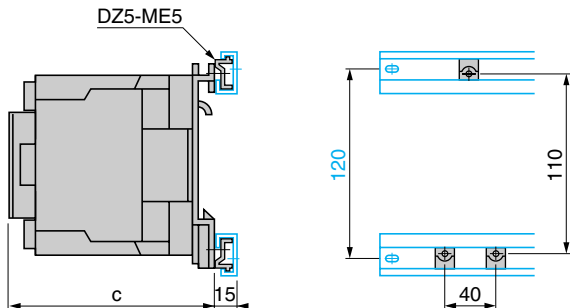

a.c. control circuit

LC1-	D40...D65	D80 & D95
c with cover	119	130

d.c. control circuit

LC1-	D40...D65	D80 & D95
c with cover	176	186
LP1-	D40 & D65	D80
c	171	181

LC1-D09 to D38 and LC1-DT20...DT60

On 2 mounting rails DZ5-MB

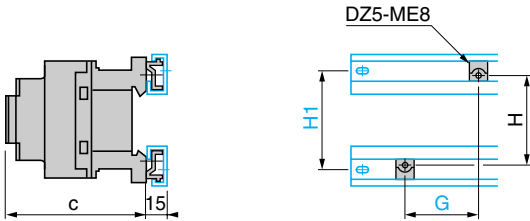

Control circuit:	a.c.		d.c.	
LC1-	D09...D18	D25...D38	D09...D18	D25...D38
c with cover	86	92	95	101
G	35	35	35	35
H	60	60	60	60
H1	70	70	70	70

4-pole contactors	a.c.		d.c.	
LC1-	DT20 & DT25	DT32 ...DT60	DT20 & DT25	DT32 ...DT60
c	92	100	101	109
G	135	40/50	35	35
H	60	60	60	60
H1	70	70	70	70

LC1-D09...D38 and LC1-DT20...DT60

On pre-slotted mounting plate AM1-PA, PB, PC

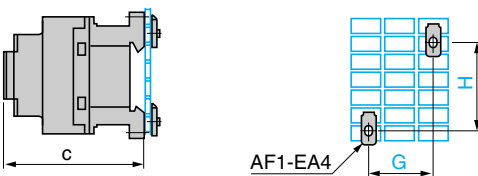

Control circuit:	a.c.		d.c.	
LC1-	D09...D18	D25...D38	D09...D18	D25...D38
c with cover	86	92	95	101
G	35	35	35	35
c with cover	86	92	95	101

4-pole contactors	a.c.		d.c.	
LC1-	DT20 & DT25	DT32 ...DT60	DT20 & DT25	DT32 ...DT60
c	80	93	118	132
G	35	35	35	35
H	60	60	60	60

LC1-D40...D95, LP1-D40...D80

On pre-slotted mounting plate AM1-PA, PB, PC

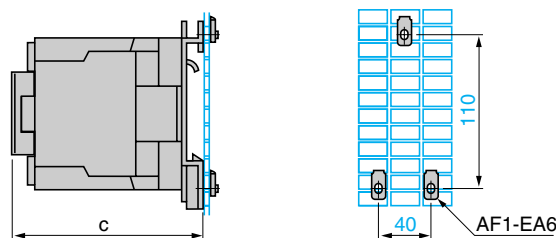

Control circuit:	a.c.		d.c.	
LC1-	D40...D65	D80 & D95	D40...D65	D80 & D95
c with cover	119	130	176	186
LP1-	-	-	D40 & D65	D80
c without cover	-	-	171	181

LC1-D09...D38

Panel mounted

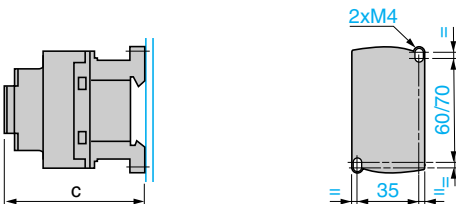

Control circuit:	a.c.		d.c.	
LC1-	D09...D18	D25...D38	D09...D18	D25...D38
c with cover	86	92	95	101

4-pole contactors	a.c.		d.c.	
LC1-	DT20 & DT25	DT32 ...DT60	DT20 & DT25	DT32 ...DT60
c with cover	90	98	90	98

LC1-D40...D95, LP1-D40 to D80

Panel mounted

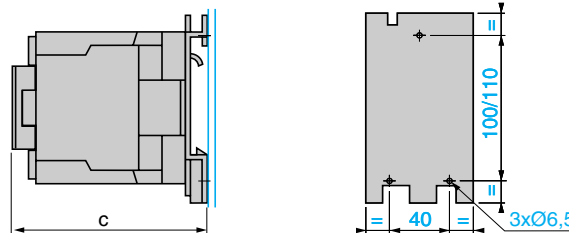

Control circuit:	a.c.		d.c.	
LC1-	D40...D65	D80 & D95	D4...D65	D80 & D95
c with cover	119	130	176	186
LP1-	-	-	D40 & D65	D80
c without cover	-	-	171	181

LC1-D115, D150

Panel mounted

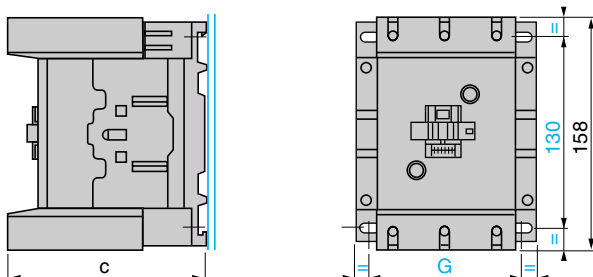

LC1-	D115	D1156	D150	D1506
c	132	115	132	115
G (3-pole)	96/110	96/110	96/110	96/110
G (4-pole)	130/144	130/144	-	-

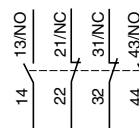
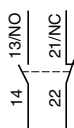
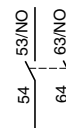
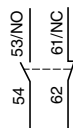
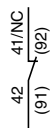
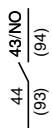
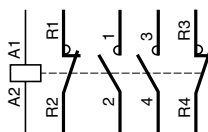
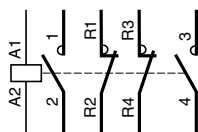
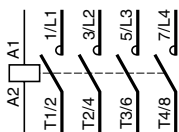
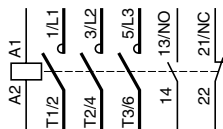

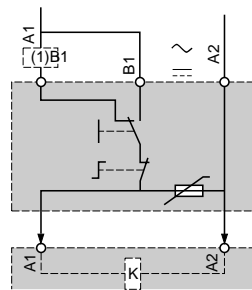
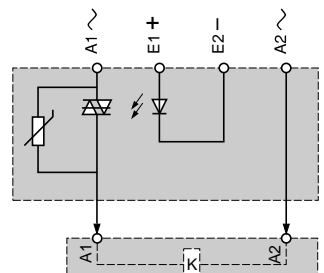
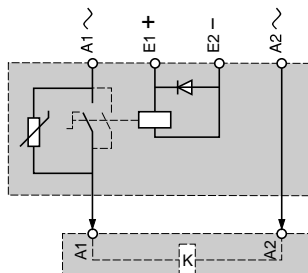
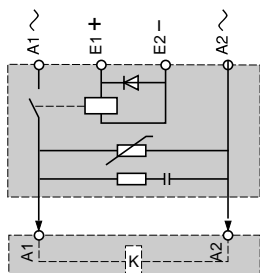
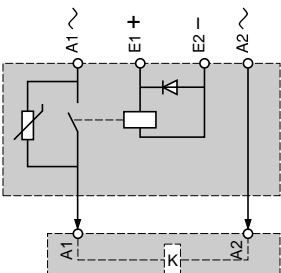
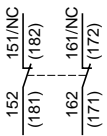
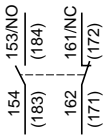
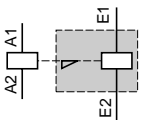
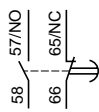
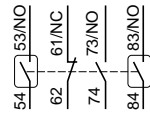
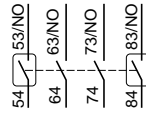
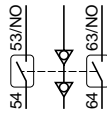
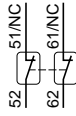
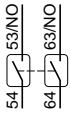

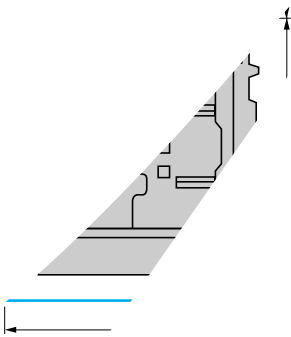

LC2- or
D115,⁷
D11F
C, F

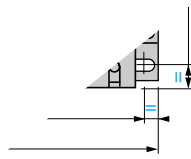

	G
d	242/256
60	310/324

Reversing contactors for motor control, horizontally mounted
LC2-D09...D150

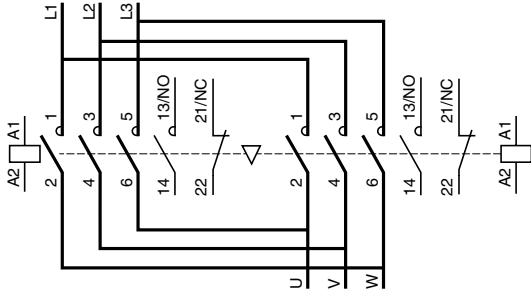

Reversing contactors for motor control with integral electrical interlocking (LAD-9R1V)

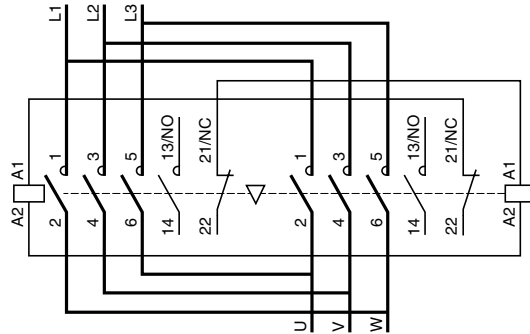

Changeover contactor pairs, horizontally mounted
LC2-DT20...DT60

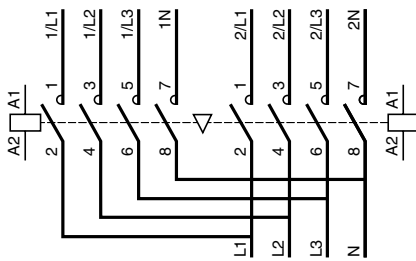

Electrical interlocking of reversing contactors fitted with:
mechanical interlock with integral electrical contacts
LA9-D●●●02

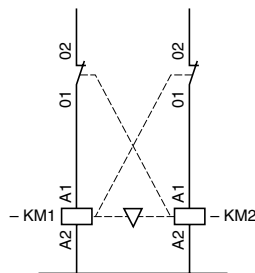
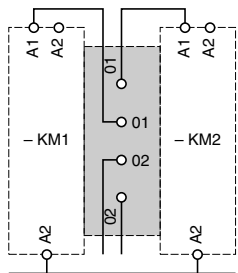

mechanical interlock without integral electrical contacts
LA9-D●●●78, LAD-9R1

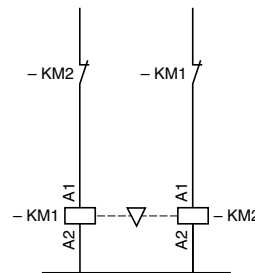

Low speed - High speed cabling kit

